

CAST IRON FLOAT STEAM TRAP SK51

FEATURES

The SK51 is a float trap dedicated to the draining of condensate in the steam lines. The SK51 has a ductile cast iron body with threaded or flanged connections with standardized face to face dimension. This steam trap is able to drain large capacities of condensate and is well adapted to the changes of flowrates. For this reason it is recommended for the draining of process like heat exchangers, autoclaves, condensers in the field of chemical processing, food and drugs industries. As a standard the SK51 is fitted with an thermostatic capsule for air elimination in starting phase. It must be installed horizontally and several mechanisms are available depending on the differential pressure.



AVAILABLE MODELS

BSP screwed end connections : G 1/2" - G 3/4" - G 1".

Connecting with flanges PN16: DN15, DN20 to DN25.

ΔP 4,5 / 10 / 14 bar.



LIMITS OF USE

Max allowed fluid pressure : PS	16 Bar
Max allowed fluid temperature TS :	+0 °C / +250 °C
Use on saturated steam	14,5 bar / +200 °C

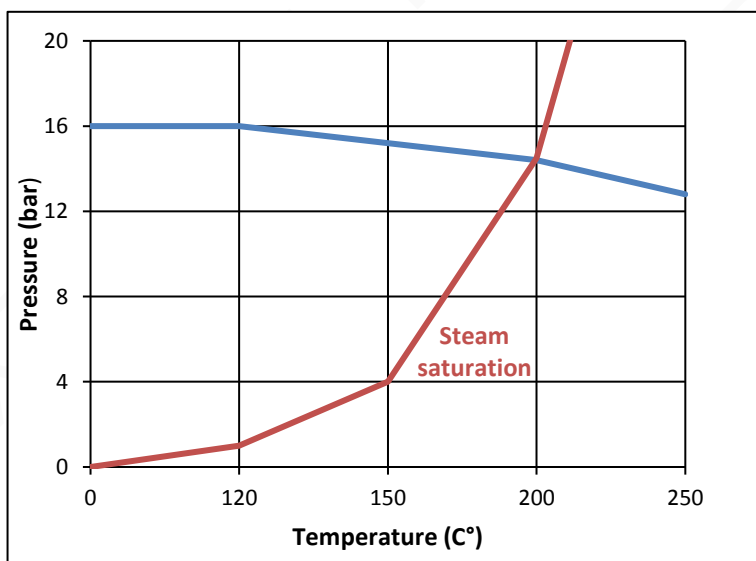

CAST IRON FLOAT STEAM TRAP SK51

DIRECTIVES AND MANUFACTURING STANDARDS

Item	Standard
Pressure equipment directive 2014/68	G 1/2" to G 1" : A4 § 3 excluded
	DN 15 to 25 : A4 § 3 excluded
Materials of cast iron	EN 1503-3
BSP thread	ISO 228
Flanges	EN 1092-2
Face to Face dimensions	EN 26554

CONSTRUCTION

N°	Item	Material
1	Body	Iron EN-GJS-400-18
2	Cover	Iron EN-GJS-400-18
3	Thermostatic capsule	Stainless steel
4	Capsule seat	Stainless steel 304
5	Float seat	Stainless steel 304
6	Ball	Stainless steel 440 C
7	Float lever	Stainless steel 304
8	Float	Stainless steel 304

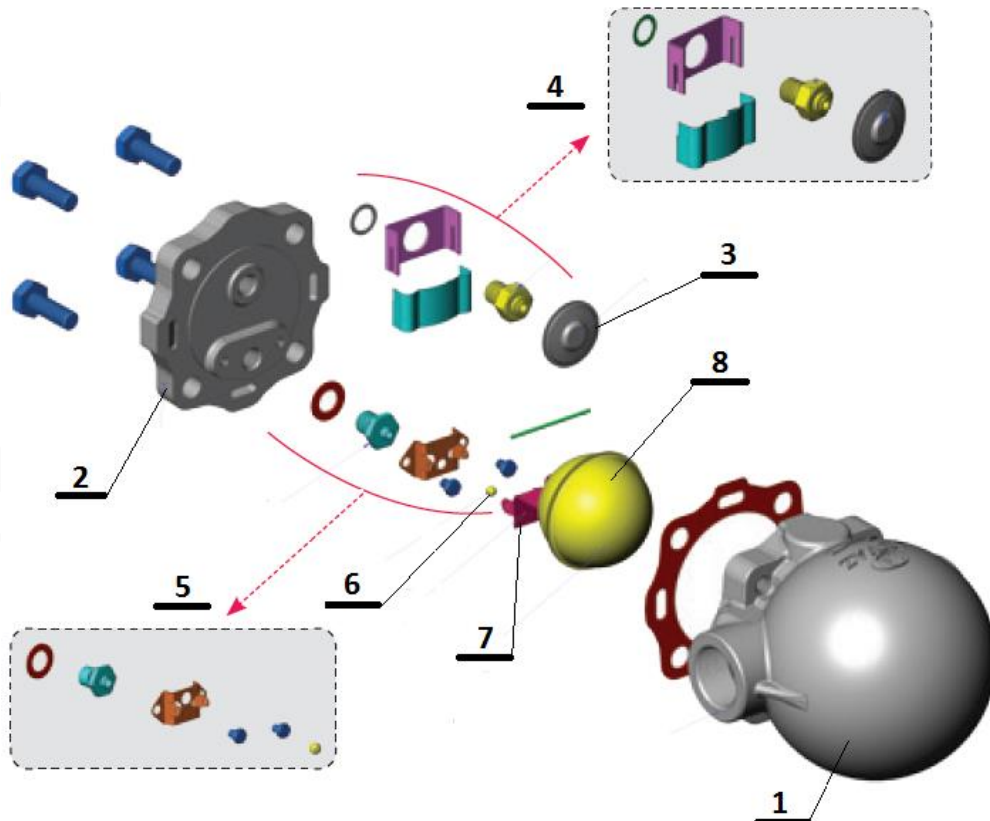
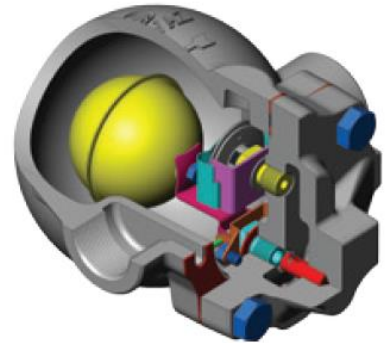

CAST IRON FLOAT STEAM TRAP SK51

DIMENSIONS (mm) AND WEIGHT (kg)

BSP screwed end connections

DN	A	B	C	ØD	ØD1	L	Weight
1/2"	150	81,5	108	98	40	122	3,3
3/4"	150	81,5	108	98	40	122	3,2
1"	167	92,5	108	120	47	145	4

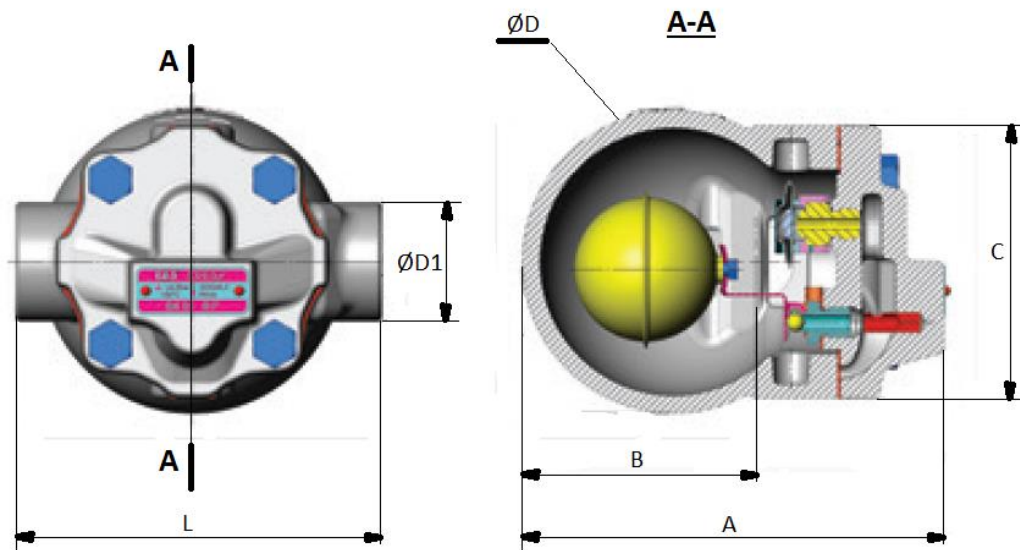

Connecting with flanges PN16

DN	A	B	C	ØD1	L	ØD	Øk	Øg	b	Drillings Nbr.	Weight
15	152,5	81,5	106	95	150	95	65	46	14	4	4,5
20	152,5	81,5	106	98	150	105	75	56	16	4	4,9
25	170	99,5	108	120	160	115	85	65	17	4	6,3

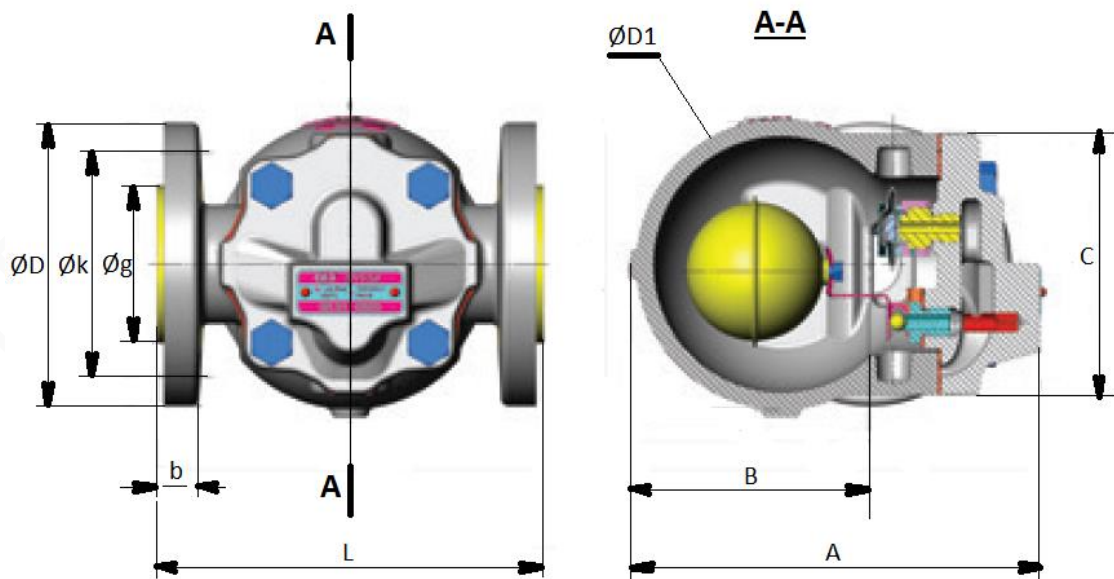

CAST IRON FLOAT STEAM TRAP SK51

FLOWRATE OF CONDENSATE (Kg/h)

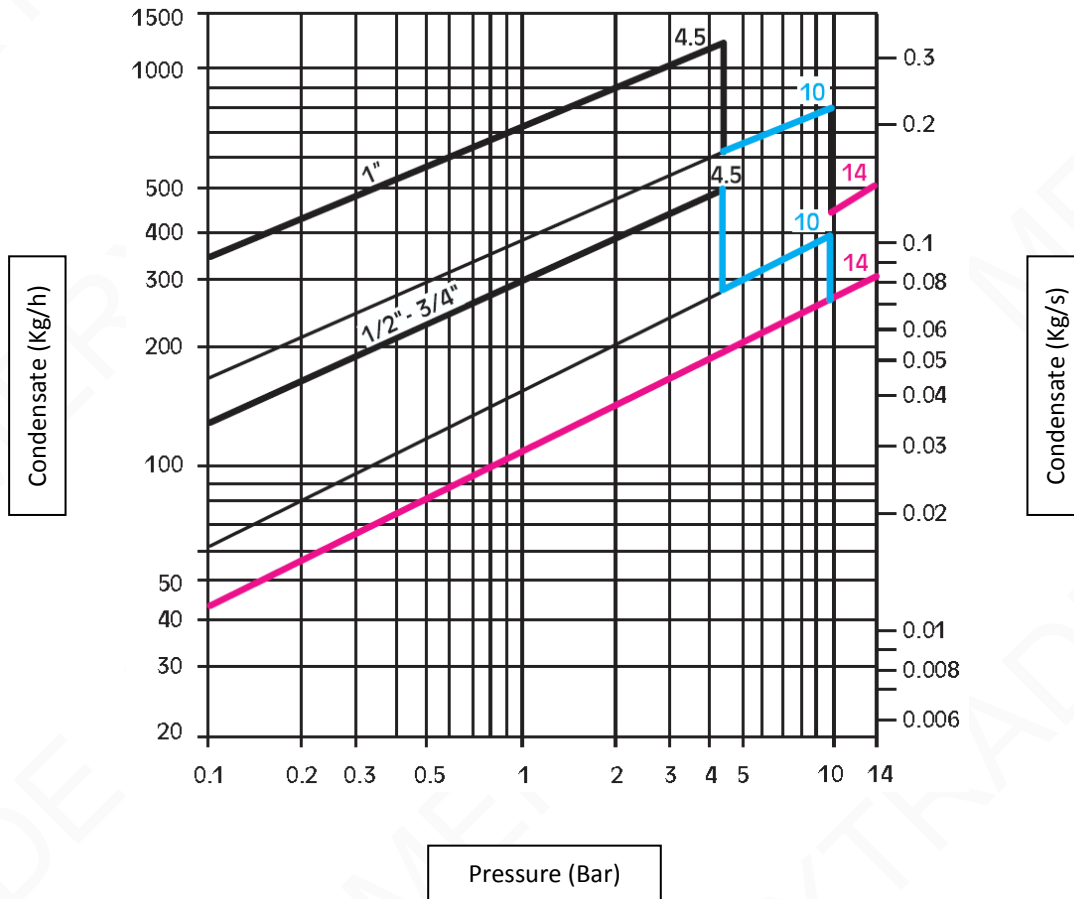

INSTALLATION

The SK51 steam trap must be installed at the lowest point of the piping to drain. As a standard, it is delivered for horizontal installation. Upsteam the trap it is recommended to install a shut-off valve and a Y strainer to avoid any damage on the seat due to the passing of impurities. Downsteam the trap must be connected to the condensate loop or to the sewage.

CAST IRON FLOAT STEAM TRAP SK51

MOUNTING

While installing the SK51, the right position has to be respected to allow the operation of the trap. Please respect the following two directions.

- 1 - SK51 has to be installed horizontally taking care of the direction of the arrow stamped on the body : from steam pipe (upstream) to condensate pie (downstream).
- 2 - Moreover the arrow written on the nameplate must be pointed to the ground.
- 3 - Before installing the trap, shut of the line and remove the pressure. Wait for complete cooling of the line before any operating.
- 4 - Clean carefully the upstream line.
- 5 - Screw the trap on the line after having verified the direction of the two arrows.
- 6 - For the flanged type, use flange's gaskets adapted to steam service.

For the bolding of flanges, use following dimensions :

Flanges PN16 Dimensions					
DN	D	K	L	Qty	∅
15	95	65	14	4	M12
20	105	75	14	4	M12
25	115	85	14	4	M12

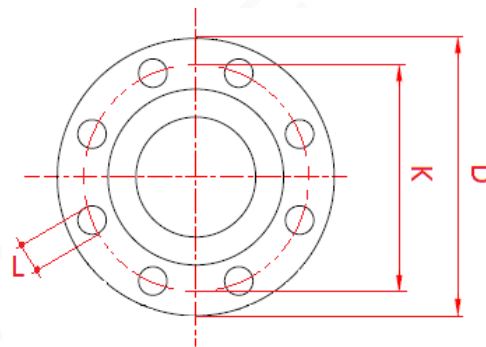

MAINTENANCE

It is not necessary to disassemble the trap from the pipe to proceed to his maintaining.

- 1 - Shutt-off the upstream valve.
- 2 - Drain the downstream line.
- 3 - Verify that there is no pressure and temperature inside the line.
- 4 - Unscrew the 4 bolts of the cover (item 2).
- 5 - Verify the state of the float (item 8). Also verify the state of the lever and the seat (item 5). Clean and/or replace the damaged parts if necessary.
- 6 - Verify the state of the capsule (item 4). Replace it if necessary and clean the seat.
- 7 - Replace the body gasket and re-assemble the cover (item 2).

SPART PARTS

DN (Theard)	DN (Flanges)	Body gasket	Internal mechanism		
			ΔP 4,5	ΔP 10	ΔP 14
1/2"	15	981203	981232	981233	981234
3/4"	20	981203	981232	981233	981234
1"	25	981204	981235	981236	981237